



Industrie Service

EU TYPE-EXAMINATION CERTIFICATE

According to Annex IV, Part A of 2014/33/EU Directive

Certificate No.: EU-BD 766

Certification Body of the Notified Body: TÜV SÜD Industrie Service GmbH
Westendstr. 199
80686 Munich - Germany
Identification No. 0036

Certificate Holder: Chr. Mayr GmbH & Co. KG
Eichenstr. 1
87665 Mauerstetten - Germany

Manufacturer of the Test Sample: Chr. Mayr GmbH & Co. KG
Eichenstr. 1
87665 Mauerstetten - Germany
(Manufacturer of Serial Production – see Enclosure)

Product: Braking device acting on the shaft of the traction sheave, as part of the protection device against overspeed for the car moving in upwards direction and braking element against unintended car movement

Type: RSR/8010._____, Size 200, 400, 600, 800, 1000, 1500

Directive: 2014/33/EU

Reference Standards: EN 81-20:2014
EN 81-50:2014
EN 81-1:1998+A3:2009

Test Report: EU-BD 766 of 2015-09-30

Outcome: The safety component conforms to the essential health and safety requirements of the mentioned Directive as long as the requirements of the annex of this certificate are kept.

Date of Issue: 2015-09-30

Date of Validity: from 2016-04-20

Achim Janocha
Certification Body "lifts and cranes"



1 Scope of application

1.1 Use as braking device – part of the the protection device against overspeed for the car moving in upwards direction – permissible brake torques and tripping rotary speeds

1.1.1 Permissible brake torques and maximum tripping rotary speeds of the traction sheave when the brake device acts on the shaft of the traction sheave while the car is moving upward

Size	Permissible brake torque [Nm]	Max. tripping rotary speed of the traction sheave [rpm]
200	200 - 560	811
200 „lang“	500 - 700	820
400 „kurz“	420 - 840	708
400 „lang“	750 - 1200	1011
600	1000 - 1600	500
800	1300 - 1900	400
1000	1840 - 2400	400
1500	2400 - 3600	400

1.1.2 Maximum tripping speed of the overspeed governor and maximum rated speed of the lift

The maximum tripping speed of the overspeed governor and the maximum rated speed of the lift must be calculated on the basis of the traction sheave's maximum tripping rotary speed as outlined above taking into account traction sheave diameter and car suspension.

$$v = \frac{D_{TS} \times \pi \times n}{60 \times i}$$

v = Tripping (rated) speed (m/s)
 D_{TS} = Diameter of the traction sheave from rope's center to rope's center (m)
 π = 3,14
 n = Rotary speed (rpm)
 i = Ratio of the car suspension

1.2 Use as braking element – part of the protection device against unintended car movement (acting in up and down direction) – permissible brake torques, tripping rotary speeds and characteristics

1.2.1 Nominal brake torques and response times with relation to a brand-new brake element

Size	Min. nominal brake torque* [Nm]	Max. nominal brake torque* [Nm]	Max. tripping rotary speed [rpm]	Maximum response times** [ms]		
				parallel without overexcitation / seriell with overexcitation		
				t_0	t_{50}	t_{90}
200	2 x 100 = 200		820	100 / 110	160 / 230	230 / 330
200		2 x 280 = 560	820	25 / 30	60 / 80	110 / 135
200 „lang“	2 x 250 = 500		820	25 / 30	50 / 65	110 / 135
200 „lang“		2 x 350 = 700	820	15 / 20	30 / 50	80 / 100
400 „kurz“	2 x 210 = 420		710	135 / 140	185 / 265	240 / 340
400 „kurz“		2 x 420 = 840	710	50 / 55	90 / 130	160 / 230
400 „kurz“ - leistungsoptimiert		2 x 350 = 700	335	30 / 40	80 / 100	100 / 150
400 „lang“	2 x 375 = 750		500	40 / 45	75 / 105	135 / 190
400 „lang“		2 x 550 = 1100	500	25 / 40	60 / 75	100 / 120
600	2 x 500 = 1000		500	85 / 100	140 / 200	185 / 260

**Annex to the EC Type-Examination Certificate
No. EU-BD 766 of 2015-09-30**



Industrie Service

600		2 x 800 = 1600	500	30 / 40	70 / 100	120 / 170
800	2 x 650 = 1300		400	80 / 100	145 / 180	170 / 230
800		2 x 950 = 1900	400	35 / 45	80 / 115	120 / 160
1000	2 x 920 = 1840		400	80 / 95	125 / 180	180 / 250
1000		2 x 1200 = 2400	400	40 / 50	95 / 130	150 / 210
1500	2 x 1200 = 2400		400	75 / 90	160 / 190	270 / 310
1500		2 x 1800 = 3600	400	35 / 40	105 / 115	180 / 240

Interim values can be interpolated

Explanations:

- * **Nominal brake torque:** Brake torque assured for installation operation by the safety component manufacturer.
- ** **Response times:** t_x time difference between the drop of the braking power until establishing X% of the nominal brake torque, t_{50} optionally calculated $t_{50} = (t_{10} + t_{90})/2$ or value taken from the examination recording

1.2.2 Assigned execution features

Type of powering / deactivation	continuous current / continuous current end
Brake control	parallel or serial
Nominal air gap	0.45 mm
Damping elements	YES
Overexcitation (Seize 200 – 1000)	at 1.5 non-release voltage
Overexcitation (Seize 1500)	at double non-release voltage

2 Conditions

- 2.1 Above mentioned safety component represents only a part at the protection device against over-speed for the car moving in upwards direction and unintended car movement. Only in combination with a detecting and triggering component in accordance with the standard (two separate components also possible), which must be subjected to an own type-examination, can the system created fulfil the requirements for a protection device.
- 2.2 The installer of a lift must create an examination instruction to fulfil the overall concept, add it to the lift documentation and provide any necessary tools or measuring devices, which allow a safe examination (e. g. with closed shaft doors).
- 2.3 The manufacturer of the drive unit must provide calculation evidence that the connection traction sheave – shaft – brake disc and the shaft itself is sufficiently safe, if the brake disc is not a direct component of the traction sheave (e. g. casted on). The shaft itself has to be statically supported in two points.
The calculation evidence must be enclosed with the technical documentation of the lift.
- 2.4 The setting of the brake torque has to be secured against unauthorized adjustment (e. g. sealing lacquer).
- 2.5 The identification drawing no. E02801000000161 including stamp dated 2015-09-30 shall be included to the EU type-examination for the identification and information of the general construction and operation and distinctness of the approved type.
- 2.6 The EU type-examination certificate may only be used in combination with the corresponding annex and enclosure (List of authorized manufacturer of the serial production). The enclosure will be updated immediately after any change by the certification holder.

**Annex to the EC Type-Examination Certificate
No. EU-BD 766 of 2015-09-30**



Industrie Service

3 Remarks

- 3.1 A code number for the brake moment effectively adjusted will be marked at the first blank in the type designation 8010. __ . __ within the permissible scope of application. A code number for design characteristics which are not directly part of the type-examination will be marked at the rest of the blanks (e. g. in the second blank: with flange plate, in the third blank: with hand release; in the fourth blank: release control and/or wear control; in the fifth blank: characteristics for electrical connection).
- 3.2 In the scope of this type-examination it was found out, that the brake device also functions as a brake for normal operation, is designed as a redundant system and therefore meets the requirements to be used also as a part of the protection device against overspeed for the car moving in upwards direction and as braking element as part of the protection device against unintended car movement.
- 3.3 Checking whether the requirements as per section 5.9.2.2 of EN 81-20:2014 (D) have been complied with is not part of this type examination.
- 3.4 Other requirements of the standard, such as reduction of brake moment respectively brake force due to wear or operational caused changes of traction are not part of this type examination.
- 3.5 This EU type-examination certificate was issued according to the following standards:
- EN 81-1:1998 + A3:2009 (D), Annex F.7 and F.8
 - EN 81-20:2014 (D), part 5.6.6.11, 5.6.7.13
 - EN 81-50:2014 (D), part 5.7 and 5.8
- 3.6 A revision of this EU type-examination certificate is inevitable in case of changes or additions of the above mentioned standards or of changes of state of the art.

**Enclosure to the EU Type-Examination Certificate
No. EU-BD 766 of 2015-09-30**



Industrie Service

Authorised Manufacturer of Serial Production – Production Sites (valid from: 2016-01-13):

**Company
Address** Chr. Mayr GmbH & Co. KG
Eichenstr. 1
87665 Mauerstetten - Germany

**Company
Address** Mayr Power Transmission Co. Ltd.
7 Fuxin Road, Jiangsu Province
215637 Zhangjiagang - P.R. China

**Company
Address** Mayr Polska Sp. z. o. o.
Rojów, ul. Hetmanska 1
63-500 Ostrzesów - Poland

- END OF DOCUMENT -

3.0. SEP. 2015

GEPRÜFT / APPROVED
 TÜV SÜD Industrie Service GmbH
 Prüflaboratorium für Produkte der Fördertechnik
 Westendstraße 199
 80686 München
 Sachverständiger / Expert
M. Neumann

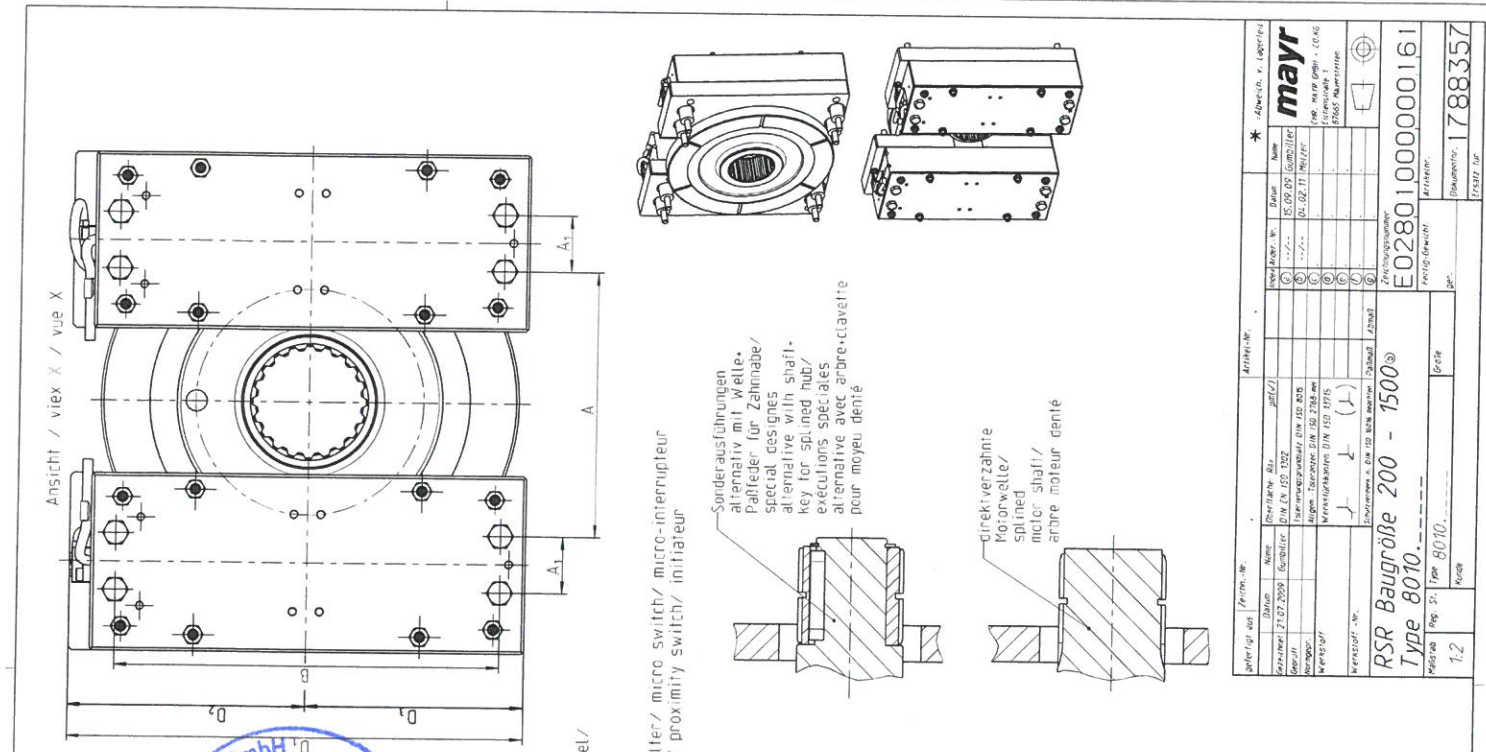

Spulenkabel/
 cable/
 câble

Mikroschalter/ micro switch/ micro-interrupteur
 @ Initiator/ proximity switch/ initiateur

Sonderausführungen
 alternativ mit Welle/
 Paßfedern für Zahnabde/
 special designs/
 alternative with shaft/
 executions spéciales
 alternative avec arbre-clavette
 pour moyeu denté

Direktverzähne/
 Motorwelle/
 splined
 motor shaft/
 arbre moteur denté

- 1) = Maße variabel, alternative Befestigungsschrauben mit entsprechendem Festigkeitsnachweis/
 dimensions variable, alternative bolts with relevant stressability proof/
 Dimensions variables, autres vis de fixation possibles avec contrôle de qualité correspondant.
- 2) = alternative Verzahnungen mit entsprechendem Festigkeitsnachweis/
 alternatives splinnings with relevant stressability proof/
 Autres cameures possibles avec contrôle de qualité correspondant
- 3) = alternative Rotordurchmesser mit entsprechendem Befestigungsnachweis/
 alternative rotor diameters with relevant calculation of spring configuration/
 Autres diamètres de rotor possibles avec contrôle des ressorts correspondant

Große/ size/ taille	Bremsmomente/ braking torque/ couples de freinage	Max. Auslässe Drehzahl/ max. over speed/ vitesse max.	2) Vorzugsverzahnungen der Motorwelle DIN 5400 / Paraz / Asplanges teeth Cannelures dentées de l'arbre du moteur	A	A ₁	B	C	C ₁	C ₂	D	D ₁	D ₂	D ₃	E	E ₁	E ₂	E ₃	F	K	R	R ₁	S	1)	
200	2x100 bis 2x260 [Ⓞ]	811	60 x 2,5 x 22 65 x 3 x 20 67 x 3 x 21	138	32	216	270	100	70	244	256	134	122	36	5	90	18	86.1	14	160	232	235	M8	1)
200 lang	2x250 bis 2x350	620	65 x 3 x 20 67 x 3 x 21 72 x 3 x 22	147	28	235	275	100	75	264	275	144	132	35	17	90	18	91.1	19	180	232	235	M8	1)
400 Kurz	2x210 bis 2x420	708	65 x 3 x 20 67 x 3 x 21 72 x 3 x 22	153	42	238	315	120	75	268	280	146	134	35	17	90	18	96.1	14	180	232	236	M10	1)
400 lang	2x375 bis 2x600	1011	72 x 3 x 22 82 x 3 x 26 90 x 3 x 28	128	42	256	290	120	50	290	303	157	146	35	17	90	18	101.1	19	200	250	253	M10	1)
600	2x500 bis 2x800	500	72 x 3 x 22 82 x 3 x 26 90 x 3 x 28	165	50	264	355	140	75	298	311	162	149	41	25	110	18	101.1	19	220	277	291	M12	1)
800	2x650 bis 2x950	400	82 x 3 x 26 90 x 3 x 28 98 x 4 x 33	169	56	300	375	150	75	336	349	181	166	41	20	124	20	108.1	22	250	311	315	M12	1)
1000	2x920 bis 2x1200	400	90 x 3 x 28 98 x 4 x 33 115.9 x 5 x 22	175	60	342	395	160	75	380	393	203	190	41	24	135	20	108.1	22	280	344	348	M16	1)
1500	2x1200 bis 2x1800	400	95 x 3 x 30 98 x 4 x 23 115 x 5 x 22	210	70	410	480	200	80	458	458	229	229	53.5	44	150	20	117.6	22	343	417	421	M15	1)

Art.Nr. 17172000
 Name: ...
 Datum: 15.09.02
 Zeichnungs-Nr.: ...
 Stückzahl: ...
 Fertigungsbereich: ...
 Zeichnungs-Nr.: E02801000000161
 Type: 8010
 Zeichnungs-Nr.: 1788357